

915nm FP Pump Laser Diode

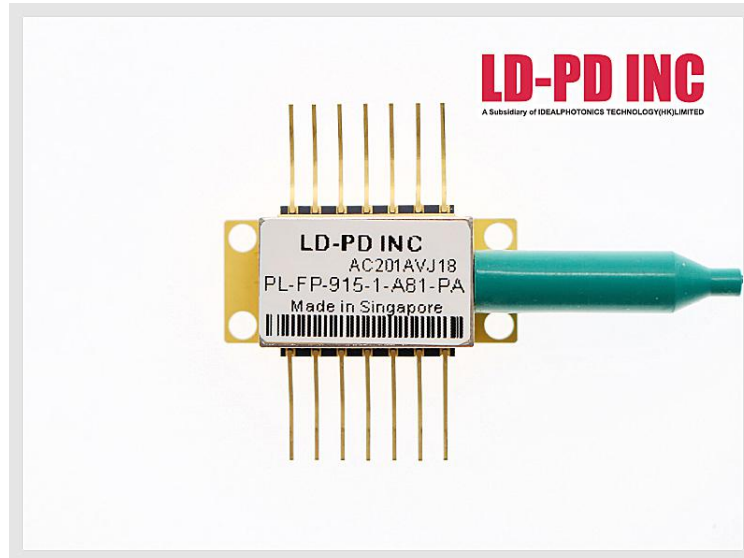

Description

The PL-FP-915-1-A81-PA is 915 nm pump laser modules uses a number of revolutionary design steps and the very latest material technologies to significantly improve scalability of the production process. The semi-cooled 45°C laser diode operation provides for a significant reduction in TEC and overall power consumption. The module meets the stringent requirements of the telecommunications industry including Telcordia GR-468-CORE for hermetic 980 nm pump modules.

The LD-PD Series pump module, which uses Fiber Bragg grating stabilization to lock the emission wavelength, provides a noise-free, narrowband spectrum even under changes in temperature, drive current, and optical feedback. Wavelength selection is available for applications requiring the highest performance in spectrum control with the highest power available.

Features

- Optical output: Up to 150mW
- FC-APC connector
- 14-PIN butterfly package
- Fiber Bragg grating stabilization
- Wavelength selection available
- Integrated thermoelectric cooler, thermistor, and monitor diode
- High dynamic range
- Excellent low power stability

Application

- Pump Laser
- Dense wavelength division multiplexing (DWDM)
- EDFAs for small package designs
- High bit-rate, high channel-count EDFAs
- CATV distribution

Laser Specifications

Electrical/Optical Characteristics(Tsub=25°C, CW bias unless stated otherwise)

Parameter	Symbol	Min	Typ	Max	Unit
Centre Wavelength	λ	910	915	920	nm
Spectral Width	$\Delta\lambda$	0.6	0.8	2.0	nm
Threshold Current	I _{th}		30	40	mA
Operating Current	I _{op}		120	200	mA
Fiber output Power	P _f	70	100	150	mW
Wavelength Tuning VS Temp	$\Delta\lambda/T$			0.01	nm/°C
Tracking Ratio(0.1Pop < P _f < Pop) ¹	TR	0.52		1.48	
Tracking error ²	TE	-48	-	+48	
Monitor diode responsivity	I _{BF}	0.5		5	uA/mW
Thermistor resistance(Tset = 25°C) ³	R _{th}	9.5	-	10.5	KΩ
PD Dark Current (VRD=5V)	I _d			0.1	uA
Extinction Ratio (PM VERSION)	PER	17	20		dB
Coupled Fiber Type	HI1060				
Forward Voltage	V _f		1.8	2.6	
Thermistor Resistance	RT	9.5	10	10.5	
Thermistor Temp. Coefficient			-4.4		
Connector	None or FC/APC				

1. The tracking ratio is a measure of the front-to-back tracking when the output power is varied. On a plot of optical power versus back-face photocurrent, a straight line is drawn between the minimum power (30 mW) and the operating power (Pop) points. The tracking ratio is defined as the ratio between measured optical power (shown as data points on the plot) to the value derived from the straight line.
2. The tracking error is defined as the normalized change of output power relative to P_f at 25°C, that is, (P_f – P_{f_25})/P_{f_25}, over case temperature range of 0 to 75°C, at constant back face monitor current corresponding to the lowest back face monitor current at P_f= Pop of 0°C, 25°C, 75°C.
3. Datasheet for Calculating Temperature from the resistance of the Thermistor is available now. You can contact us for details.

Spectrum

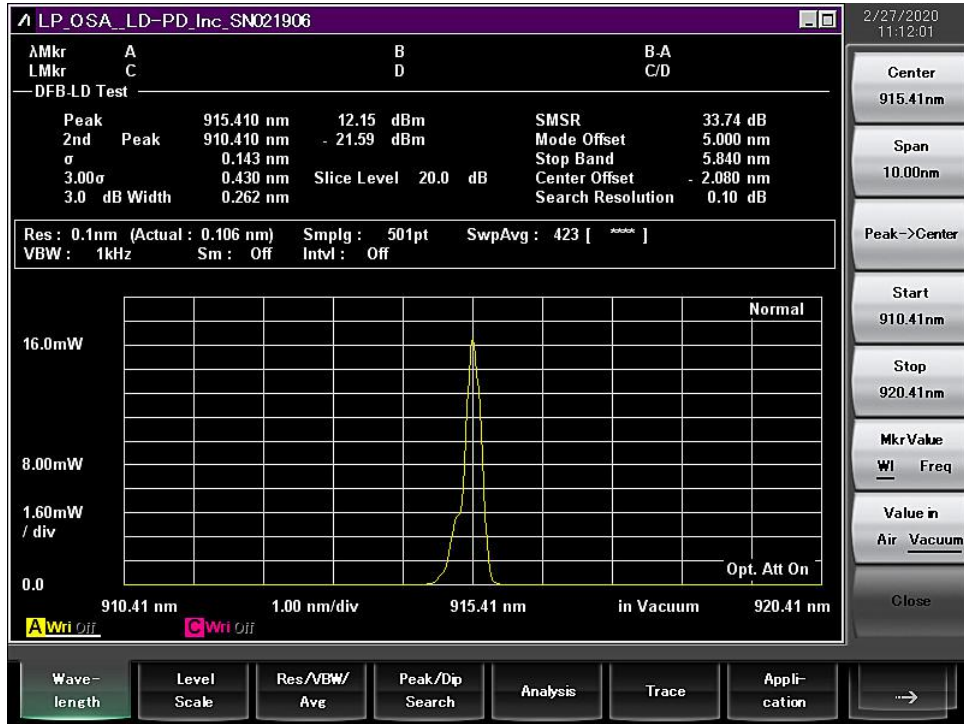

L-I Curve

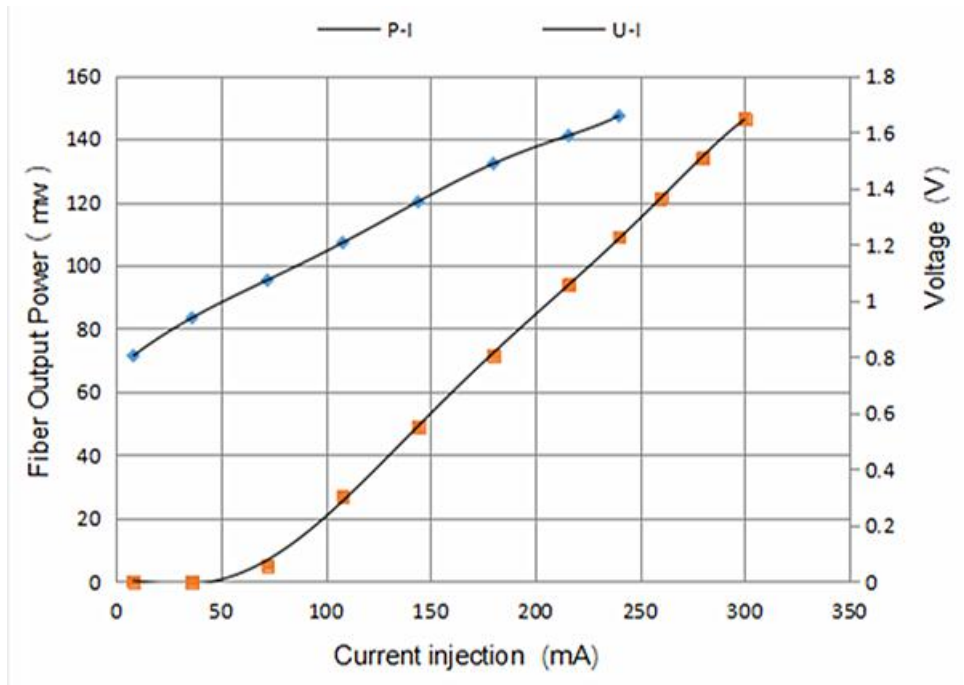

Package Size and Pin definition

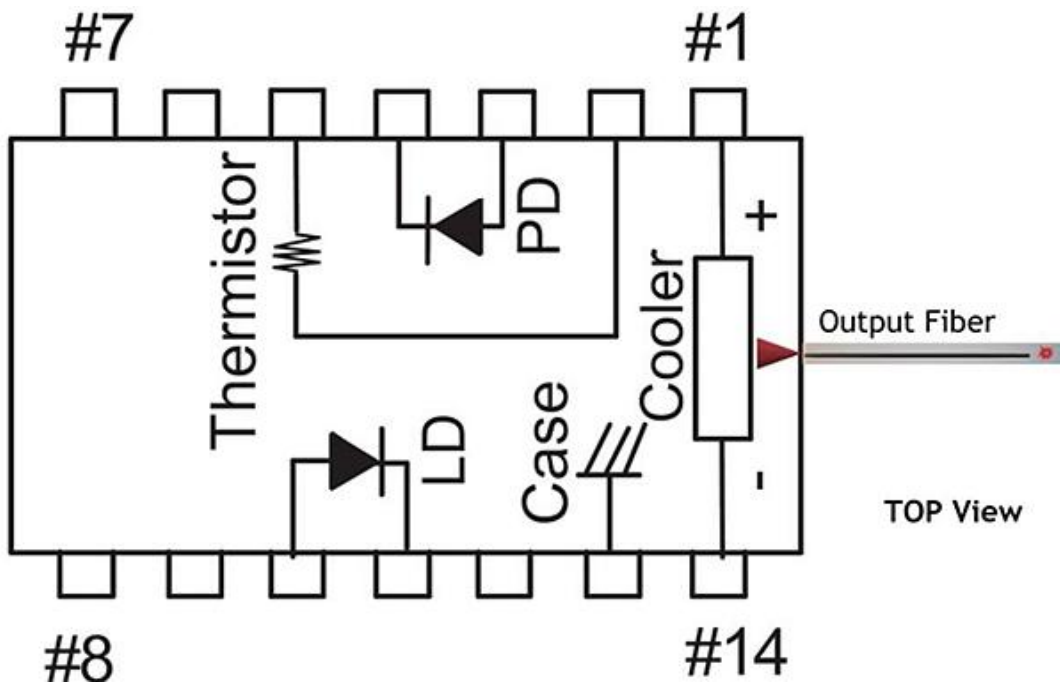
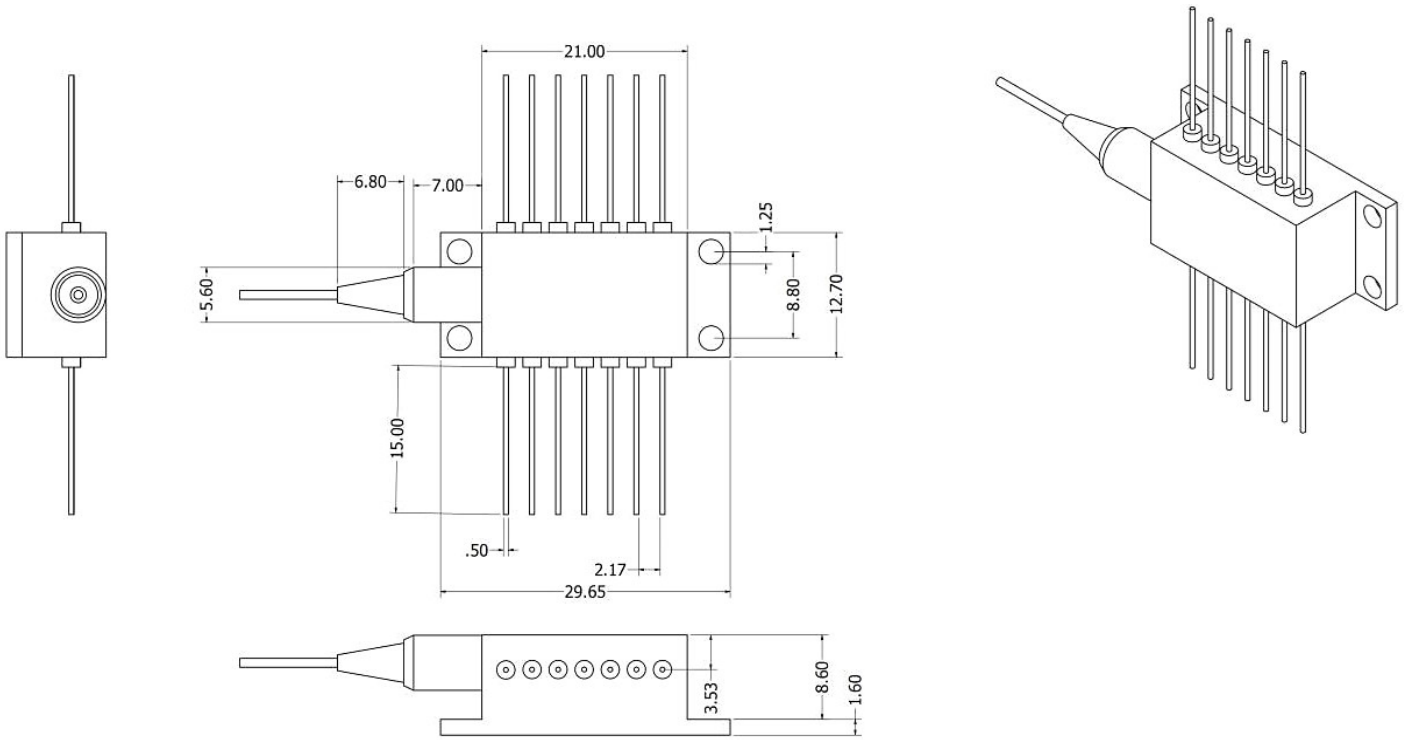

1	Thermoelectric Cooler (+)	8	N/C
2	Thermistor	9	N/C
3	PD Monitor Anode (-)	10	SLD Anode (+)
4	PD Monitor Cathode (+)	11	SLD Cathode (-)
5	Thermistor	12	N/C
6	N/C	13	Case Ground
7	N/C	14	Thermoelectric Cooler (-)

HI 1060 Fiber Nominal Characteristics and Tolerances

Parameters	Specification
Cut off wavelength	920nm
Max Attenuation	2.1dB/km
Cladding Diameter	125um
Coating Diameter	250um
Core Cladding Concentricity	≤0.5um
Mode Field diameter	5.9 um

Item	Symbol	Unit	Min	Typ	Max	Testing Condition
Case Temperature	T_{OP}	°C	-5	25	70	
Chip Temperature	T_{LD}	°C	+10	25	50	
Operating Current	I_{f-max}	mA	0	150	200	
Forward Voltage	V_R	V	0.8	1.2	1.8	
TEC Current	I_{TEC}	A	-	1.2	2.0	
Tec Voltage	V_{TEC}					
Axial Pull Force		N	-	-	5N	3x10s
Side Pull Force		N	-	-	2.5N	3x10s
Fiber Bend Radius			16mm			-
Reverse Voltage (LD)		V	-	-	1.8	C=100pF,R=1.5KΩ, HBM
Reverse Voltage(PD)	V_{PD}	V	-	-	10	C=100pF,R=1.5KΩ, HBM
LD electrostatic Discharge	V_{ESD-LD}	V		-	1000	
PD electrostatic Discharge	V_{ESD-PD}	V		-	500	
PD Forward Current	I_{PF}	mA		-	10	
Lead Soldering time		S		-	10s	300°C
Store Temperature	T_{STG}	°C	-40	-	+85	2000hr
Operating Temperature	T_{OP}	°C		-		
Relative Humidity	RH		5%		95%	

Absolute maximum ratings are the maximum stresses that may be applied to the module for short periods of time without causing damage and are listed in Table 5. Stresses in excess of the absolute maximum ratings can cause permanent damage to the device. Exposure to absolute maximum ratings for extended periods of time or exposure to more than one absolute maximum rating simultaneously may adversely affect device reliability. Specifications may not necessarily be met under these conditions.

Ordering Info

PL-FP-□□□□-☆-A8▽-XX

□□□□: Wavelength

405: 405nm

633: 633nm

680: 680nm

850: 850nm

915: 915nm

980: 980nm

1550: 1550nm

☆ : Output Power

A: 50mW

B: 100mW

C: 150mW

▽: Wavelength Tolerance

1: ±1nm

2: ±2nm

XX: Fiber and Connector Type

SA=HI1060+ FC/APC

SP=HI1060+ FC/PC

PP=PM 980 + FC/PC

PA=PM980+ FC/APC

Labeling

Laser Safety

The LD-PD pump laser module emits hazardous invisible laser radiation. The pump laser module emits hazardous invisible laser radiation. Due to the small size of the pump module, the box packaging is labeled with the laser radiation hazard symbol and safety warning labels shown below

User Safety

Safety and Operating Considerations

The laser light emitted from this laser diode is invisible and may be harmful to the human eye. Avoid looking directly into the fiber when the device is in operation.

CAUTION: THE USE OF OPTICAL INSTRUMENTS WITH THIS PRODUCT INCREASES EYE HAZARD.

Operating the laser diode outside of its maximum ratings may cause device failure or a safety hazard. Power supplies used with this component cannot exceed maximum peak optical power.

CW laser diodes may be damaged by excessive drive current or switching transients. When using power supplies, the laser diode should be connected with the main power on and the output voltage at zero. The current should be increased slowly while monitoring the laser diode output power and the drive current. Careful attention to heatsinking and proper mounting of this device is required to ensure specified performance over its operating life. To maximize thermal transfer to the heatsink, the heatsink mounting surface must be flat to within .001inch and the mounting screws must be torqued down to 1.5 in/lb.

ESD PROTECTION—Electrostatic discharge (ESD) is the primary cause of unexpected laser diode failure. Take extreme precaution to prevent ESD. Use wrist straps, grounded work surfaces, and rigorous antistatic techniques when handling laser diodes.