

1335nm FP Single-Mode 14-Pin Butterfly Module Laser Diodes

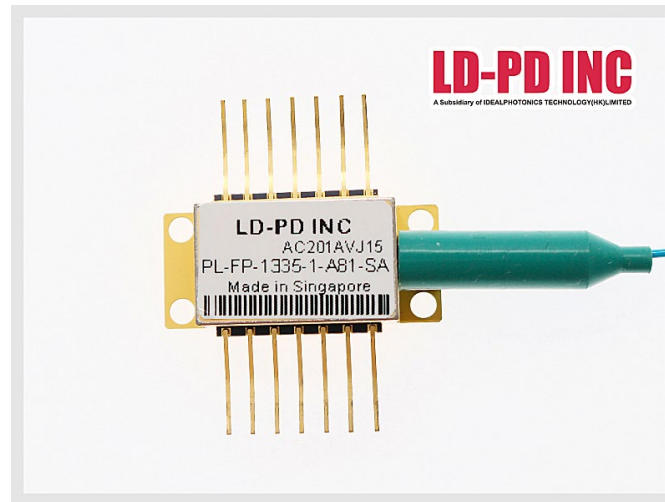

Description:

The PL-FP-1335-A-A81-SA High brightness, high quality, and high reliability are the foundation of our single mode product line. LD-PD's 1335nm single mode laser modules are available with up to 70mW of continuous output power from a 14-pin butterfly packaged fiber. All chips are mounted on a 2.1mm COS within the package and come standard with an internal thermistor, TEC, and photodiode. LD-PD's trademark laser chip design offers un-measurable degradation and long lifetimes that make our chips among the most reliable in the industry today. Our 1335nm single mode line serves a broad range of applications including optical data storage, printing, laser ranging, illumination, defense, spectral analysis, and graphics.

Features:

- Optical output: 100mW
- FC-APC connector
- Efficient coupling into single mode fiber
- 14-pin butterfly package
- CW or pulsed operation
- Internal monitor PD and TEC
- SM or PM Fiber (ø0.9mm)

Optional:

- Printing
- Optical Data Storage
- Spectral Analysis
- Graphics
- Laser Ranging
- Illumination
- Defense

Laser Specifications:

Electrical/Optical Characteristics (Tsub=25°C, CW bias unless stated otherwise)

Parameter	Symbol	Min	Typ	Max	Unit
Centre Wavelength	λ	1320	1335	1350	nm
Spectral Width	$\Delta\lambda$	0.1	0.5	2.0	nm
Threshold Current	I _{th}		30	40	mA
Operating Current	I _{op}		150	200	mA
Fiber output Power	P _f	50	70	100	mW
PD Dark Current (VRD=5V)	I _d			0.1	uA
Extinction Ratio PM VERSION	PER	17	20		dB
Coupled Fiber Type	SMF-28E				
Forward Voltage	V _f		1.8	2.5	V
Thermistor Resistance	R _T	9.5	10	10.5	K Ω
Thermistor Temp. Coefficient			-4.4		%/°C
Connector	FC/APC				

Spectrum:

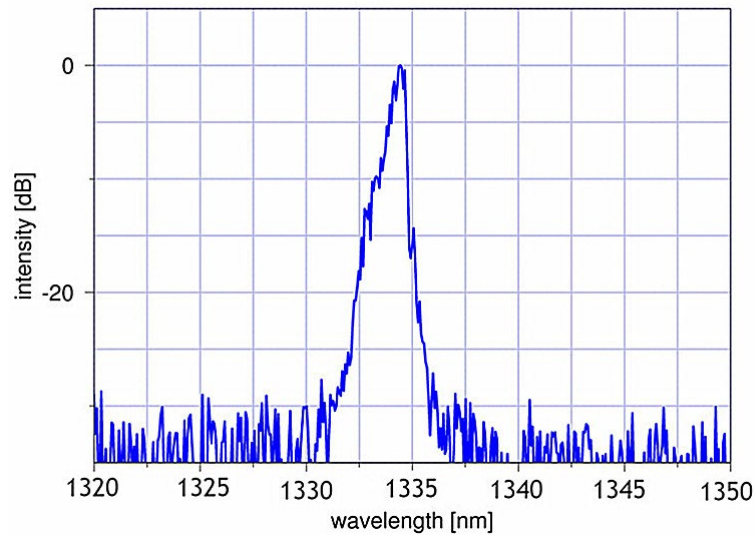

L-I Curve:

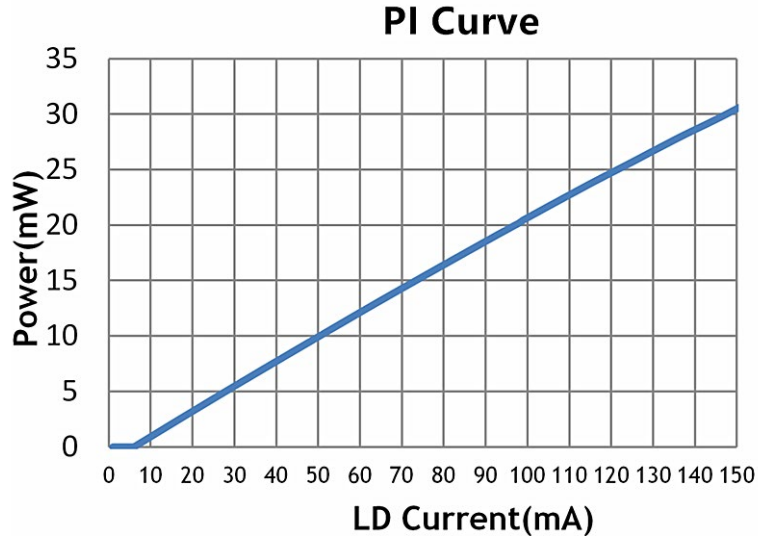

Package Size:

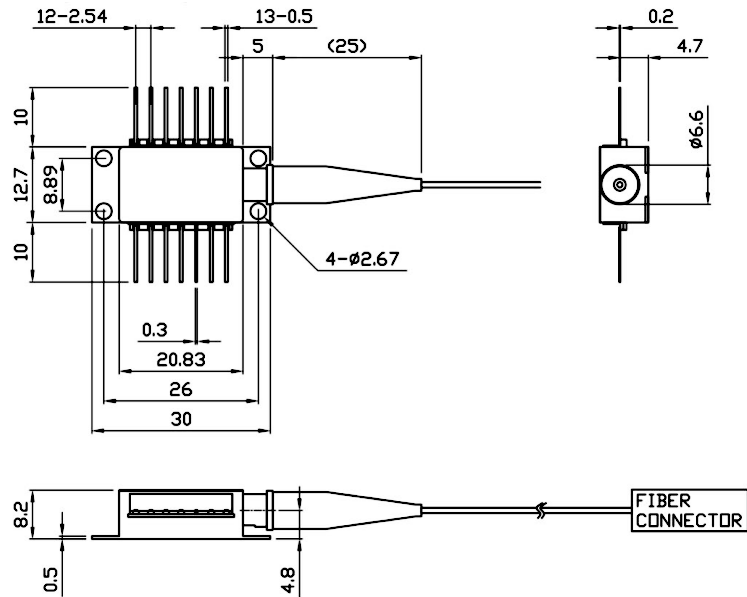

Pin definition:

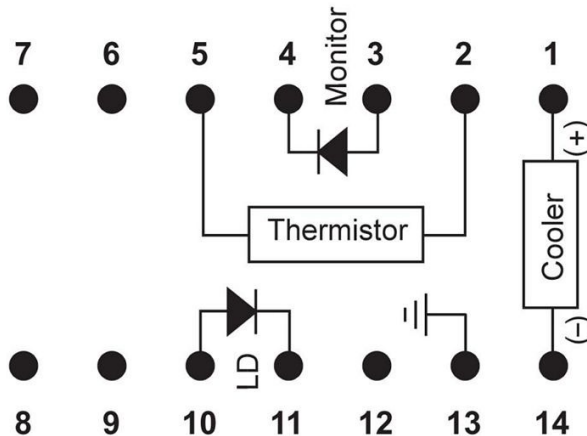

1	Thermoelectric Cooler (+)	8	N/C
2	Thermistor	9	N/C
3	PD Monitor Anode (-)	10	Laser Anode (+)
4	PD Monitor Cathode (+)	11	Laser Cathode (-)
5	Thermistor	12	N/C
6	N/C	13	Case Ground
7	N/C	14	Thermoelectric Cooler (-)

Absolute Maximum Ratings:

Item	Unit	Min	Typ	Max
Case Temperature	°C	-5	25	70
Chip Temperature	°C	+10	25	40
Operating Current	mA	0	150	200
Forward Voltage	V	0.8	1.2	1.8
TEC Current	A	-	1.2	1.4
Reverse Voltage (LD)	V	-	-	1.8
Reverse Voltage (PD)	V	-	-	10

Ordering Info:

PL-FP-□□□□- A8▽-XX-FBG

□□□□: Wavelength

405: 405nm

633: 633nm

680: 680nm

850: 850nm

1335: 1335nm

1550: 1550nm

: Output Power

1: 30mW

2: 70mW

▽: Wavelength Tolerance

1: ±1nm

2: ±2nm

XX: Fiber and Connector Type

SA=SMF-28E+ FC/APC , SP=SMF-28E+ FC/PC

PP=PM Fiber+ FC/PC , PA=PM Fiber+ FC/APC