

1653.7nm DFB Laser diode for CH4 Sensing

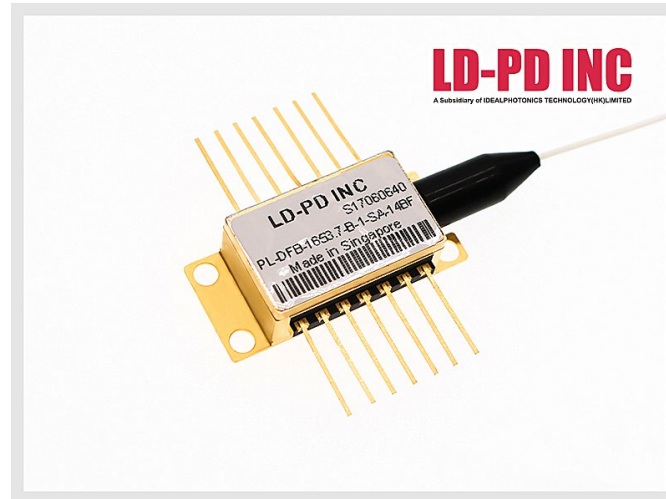

Description:

The PL-DFB-1653.7-A-A81 1653.7nm DFB laser diode module made by LD-PD is a cost effective, highly coherent laser source. The DFB laser diode chip is packaged in an industry standard hermetically sealed 14 pin butterfly package with TEC and PD Built in.

Features:

- Narrow Linewidth < 2MHz
- Excellent wavelength control and stability
- Industry Standard 14 pin Butterfly package
- Mode-Hop free tuning
- Excellent reliability
- Customer specific wavelengths available

Application:

- Tunable diode laser absorption spectroscopy
- CH4 Monitoring

Electrical/Optical Characteristics:

Tsub=25°C, CW bias unless stated otherwise

Parameter	Symbol	Min	Typ	Max	Unit
Centre Wavelength	λ	1653.2	1653.7	1654.2	nm
Side Mode Suppression Ratio	SMSR	30	40		dB
Threshold Current	I _{th}		20	30	mA
Operating Current	I _{op}		80	120	mA
Chip output Power	P _f	10	15	30	mW
Quantum Efficiency	η	0.08	0.12		mW/mA
Current Tuning Coefficient	$\Delta\lambda/\Delta I$		0.015		nm/mA
Temperature Tuning Coefficient	$\Delta\lambda/\Delta T$		0.12		nm/K
Forward Voltage	V _f		1.3	2	V
Thermistor Resistance	R _T	9.5	10	10.5	K Ω
Thermistor Temp. Coefficient			-4.4		%/°C
Connector	FC/APC				

Spectrum:

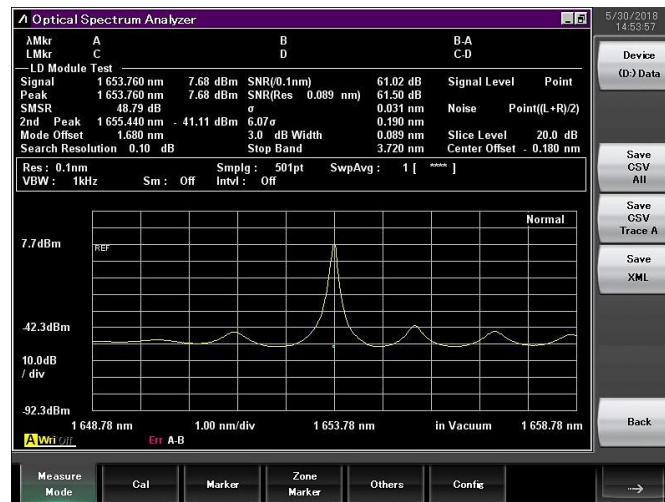

L-I Curve:

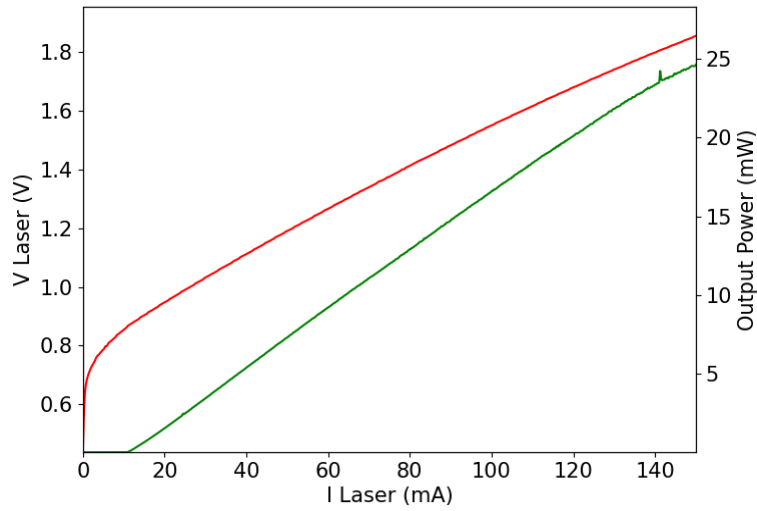

Tuning Characteristics

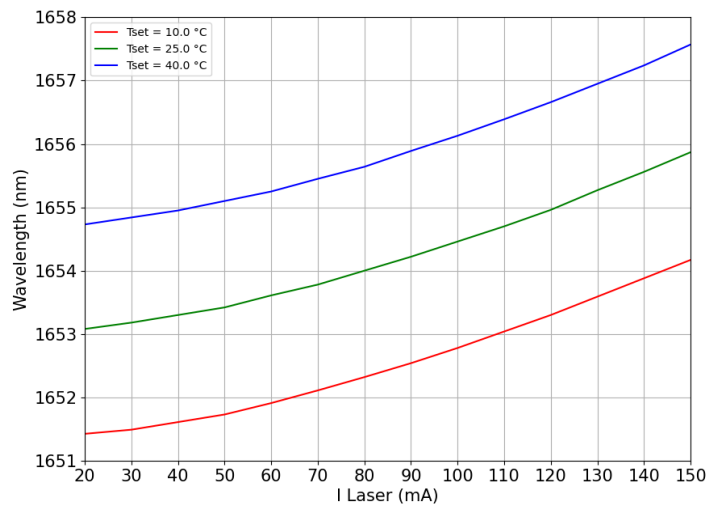

DFB Linewidth Testing Result:

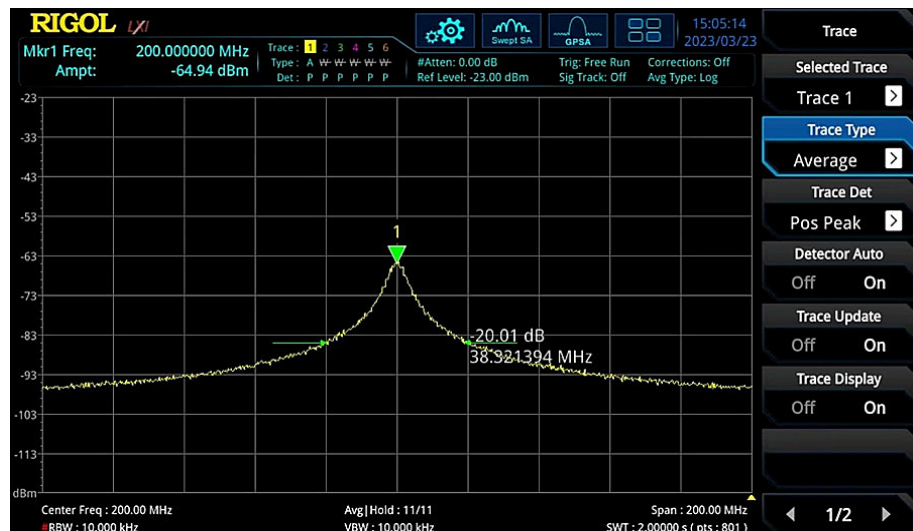

Wavelength Stability:

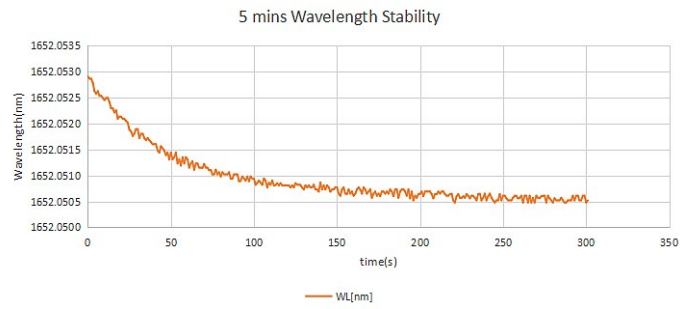

Mode hopping tuning Range:

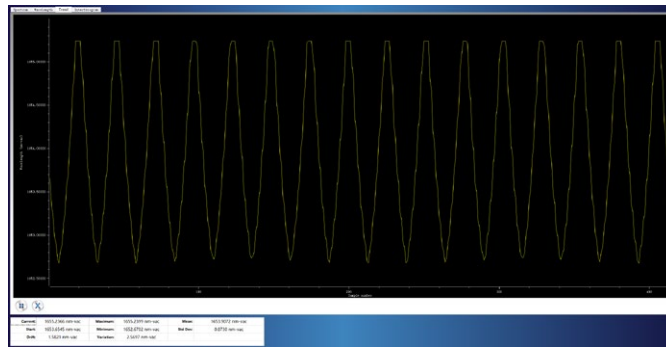

Beam Quality:

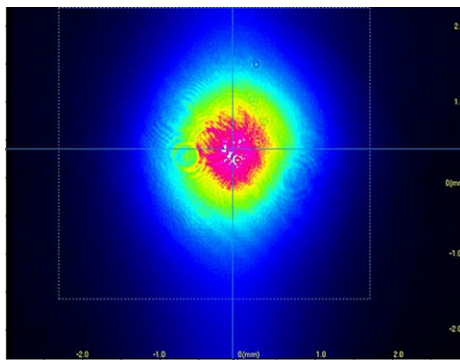

2D

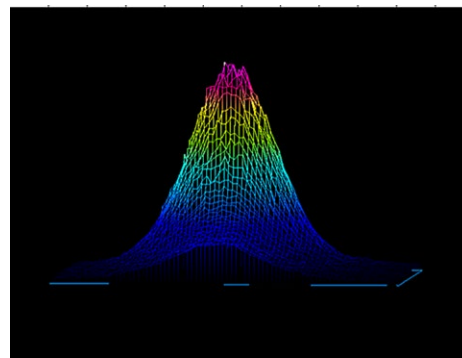

3D

Camera Analysis:

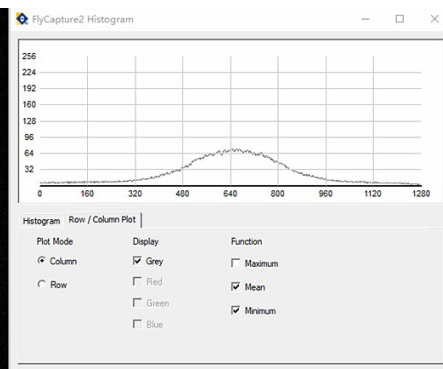
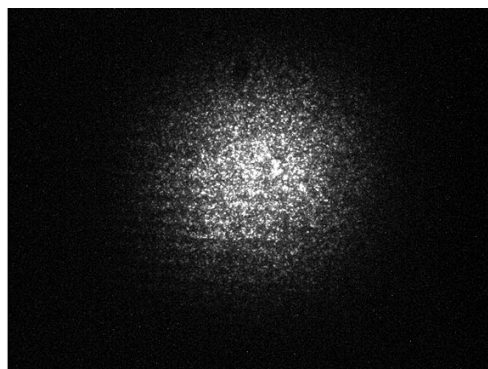

Package Size:

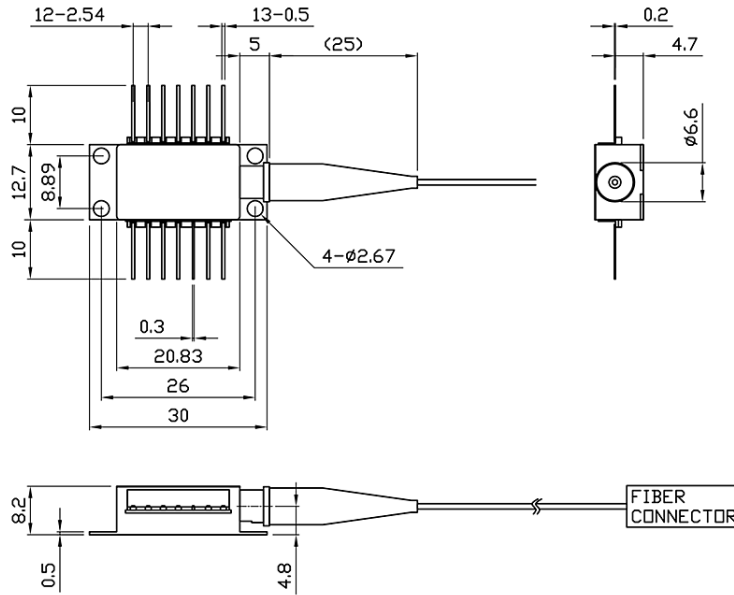

Pin definition:

Schematic Diagram (Top View)

Pin definition

TYPE A

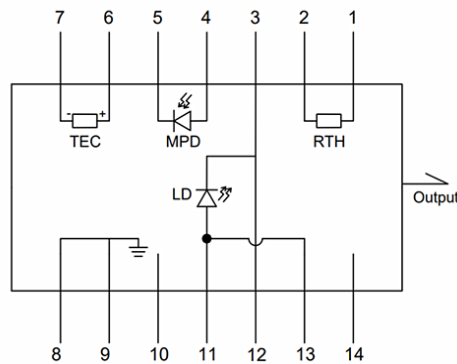

Pin Connection:

PIN#	Function	PIN#	Function
1	Thermistor	8	Case Ground
2	Thermistor	9	Case Ground
3	LD(-)	10	NC
4	Detector (+)	11	LD(+)
5	Detector (-)	12	LD (-), RF
6	TEC (+)	13	LD(+)
7	TEC (-)	14	NC

TYPE B

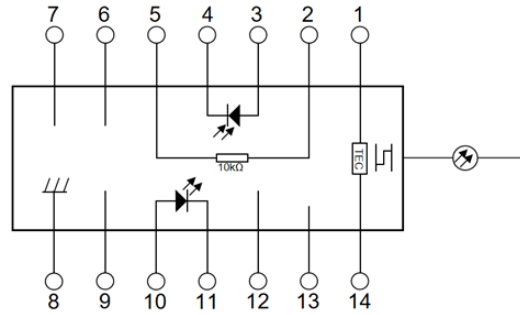

Pin Connection:

PIN#	Function	PIN#	Function
1	Thermistor	8	NC
2	Thermistor	9	NC
3	NC	10	NC
4	PD Monitor Anode (-)	11	Laser Anode (+), Case Ground
5	PD Monitor Cathode (+)	12	RF Laser Input Cathode (-)
6	Thermoelectric Cooler (+)	13	Laser Anode (+), Case Ground
7	Thermoelectric Cooler (-)	14	NC

Absolute Maximum Ratings:

Item	Unit	Min	Typ	Max
Case Temperature	°C	-5	25	70
Chip Temperature	°C	+10	25	40
Operating Current	mA	0	100	150
Forward Voltage	V	0.8	1.2	1.8
TEC Current	A	-	-	1.2
Reverse Voltage (LD)	V	-	-	2.0
Reverse Voltage (PD)	V	-	-	20

CH₄:

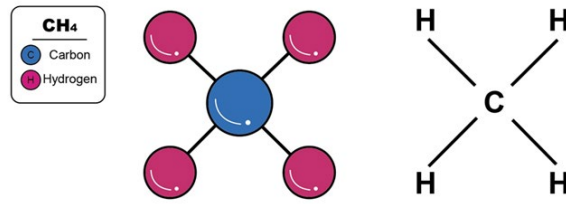

TDLAS: 1650.9nm 1653.7nm

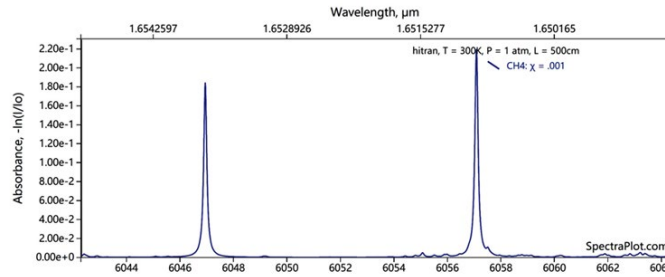

Ordering Info:

PL-DFB-□□□□-☆-▽-XX-14BF

□□□□: Wavelength

1512: 1512nm

1653.7: 1653.7nm

☆: Output Power

A: 10mW

B: 20mW

▽: Wavelength Tolerance

1: ±1nm

2: ±2nm

XX: Fiber and Connector Type

SA=SMF-28E+ FC/APC

SP=SMF-28E+ FC/PC

PA=PM Fiber+ FC/APC

PP=PM Fiber+ FC/PC