

## 1310nm FP SM Module Laser Diodes

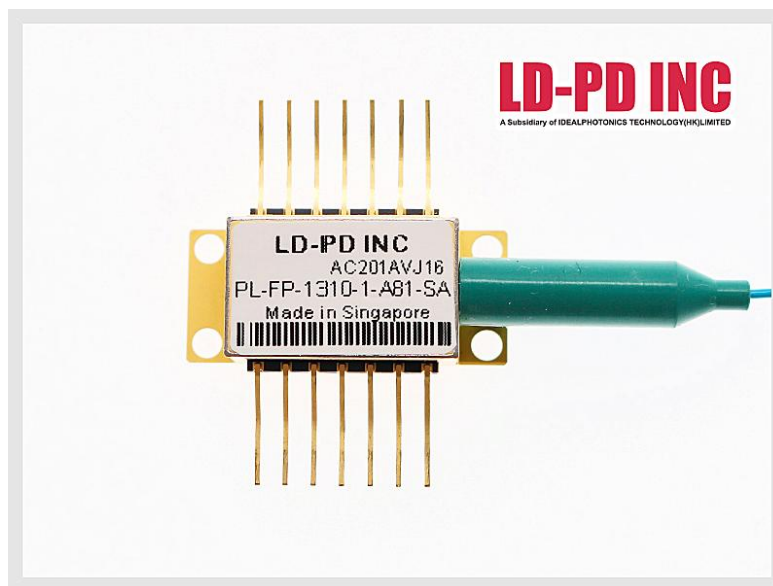

### Description:

The PL-FP-1310-A-A81-SA High brightness, high quality, and high reliability are the foundation of our single mode product line. LD-PD's 1310nm single mode laser modules are available with up to 70mW of continuous output power from a 14-pin butterfly packaged fiber. All chips are mounted on a 2.1mm COS within the package and come standard with an internal thermistor, TEC, and photodiode. LD-PD's trademark laser chip design offers un-measurable degradation and long lifetimes that make our chips among the most reliable in the industry today. Our 1310nm single mode line serves a broad range of applications including optical data storage, printing, laser ranging, illumination, defense, spectral analysis, and graphics.

### Features

- Optical output: 30mW
- FC-APC connector
- Efficient coupling into single mode fiber
- 14-pin butterfly package
- CW or pulsed operation
- Internal monitor PD and TEC
- SM or PM Fiber (ø0.9mm)

## Application

- Printing
- Optical Data Storage
- Spectral Analysis
- Graphics
- Laser Ranging
- Illumination
- Defense

## Limit parameter

Electrical/Optical Characteristics (Tsub=25°C, CW bias unless stated otherwise)

Parameter	Symbol	Min	Typ	Max	Unit
Centre Wavelength	$\lambda$	1305	1310	1315	nm
Spectral Width	$\Delta\lambda$	3	6	9	nm
Threshold Current	I <sub>th</sub>		80	100	mA
Operating Current	I <sub>op</sub>		100	150	mA
Fiber output Power	P <sub>f</sub>	10	15	20	mW
PD Dark Current (VRD=5V)	I <sub>d</sub>			0.1	uA
Extinction Ratio (PM VERSION)	PER	17	20		dB
Coupled Fiber Type	SMF-28E				
Forward Voltage	V <sub>f</sub>		1.8	2.5	V
Thermistor Resistance	R <sub>T</sub>	9.5	10	10.5	KΩ
Thermistor Temp. Coefficient			-4.4		%/°C
Connector	FC/APC				

## Spectrum



## L-I Curve

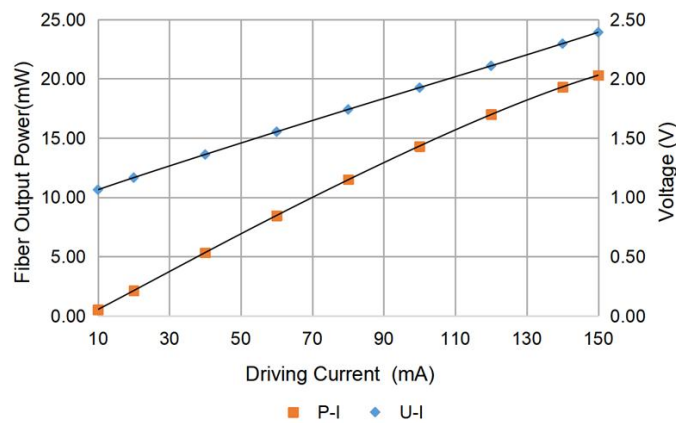

## Package Size

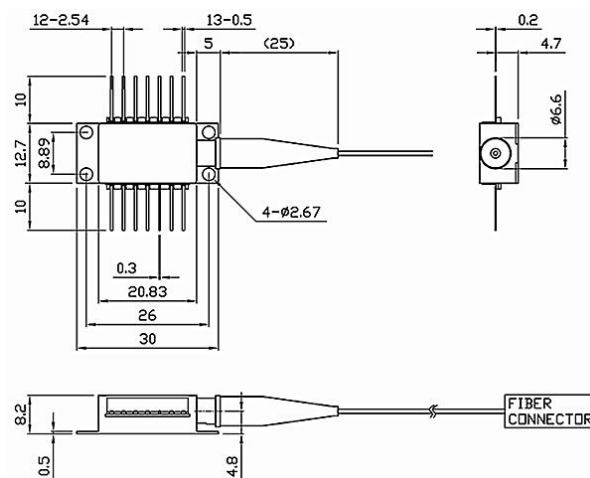

## Pin definition

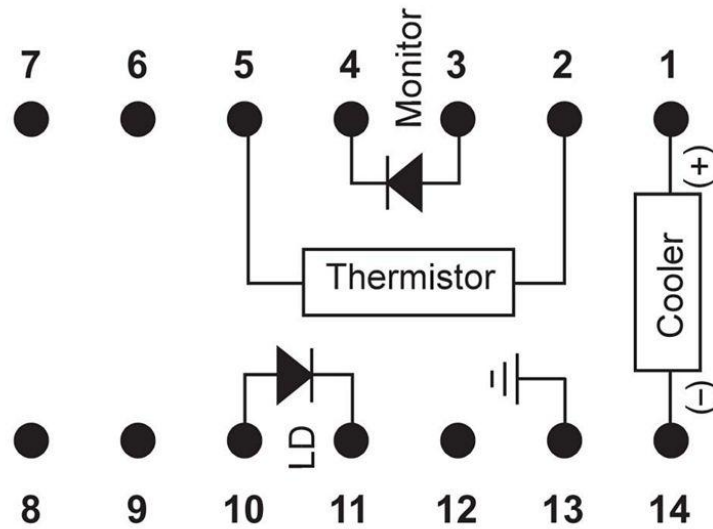

1	Thermoelectric Cooler (+)	8	N/C
2	Thermistor	9	N/C
3	PD Monitor Anode (-)	10	Laser Anode (+)
4	PD Monitor Cathode (+)	11	Laser Cathode (-)
5	Thermistor	12	N/C
6	N/C	13	Case Ground
7	N/C	14	Thermoelectric Cooler (-)

## Absolute Maximum Ratings

Item	Unit	Min	Typ	Max
Case Temperature	°C	-5	25	70
Chip Temperature	°C	+10	25	40
Operating Current	mA	0	120	125
Forward Voltage	V	0.8	1.2	1.8
TEC Current	A	-	1.2	1.4
Reverse Voltage (LD)	V	-	-	1.8
Reverse Voltage(PD)	V	-	-	10

## Ordering Info

PL-FP-□□□□-☆-A8▽-XX

□□□□: Wavelength

405: 405nm

633: 633nm

680: 680nm

850: 850nm

1310: 1310nm

\*\*\*\*\*

1550: 1550nm

☆: Output Power

A: 10mW

B: 30mW

▽: Wavelength Tolerance

1: ±5nm

2: ±10nm

XX: Fiber and Connector Type

SA=SMF-28E+ FC/APC

SP=SMF-28E+ FC/PC

PP=PM Fiber+ FC/PC

PA=PM Fiber+ FC/APC